

# Turbine Flowmeter

## Supmea

### Headquarters

5th floor, Building 4, Singapore Hangzhou Science Technology Park, No. 6 street,  
Hangzhou Economic Development Area, Hangzhou 310018, China

### Singapore

2 Venture Drive #11-30 Vision Exchange Singapore

✉ [info@supmea.com](mailto:info@supmea.com)

🌐 [www.supmea.com](http://www.supmea.com)

Supmea Automation Co., Ltd.

---

## **Preface**

- Thank you for purchasing our product.
- This manual is about the various functions of the product, wiring methods, setting methods, operating methods, troubleshooting methods, etc.
- Please read this manual carefully before operation, use this product correctly to avoid unnecessary losses due to incorrect operation.
- After you finish reading, please keep it in a place where it can be easily accessed at any time for reference during operation.

## **Note**

- Modification of this manual's contents will not be notified as a result of some factors, such as function upgrading.
- We try our best to guarantee that the manual content is accurate, if you find something wrong or incorrect, please contact us.
- The content of this manual is strictly prohibited from reprinting or copying.

## **Version**

U-LWGY-SUP-EN2

---

## Confirm the contents of the package

Please confirm the product and accessories after unpacking. Once the product is wrong, the quantity is wrong or there is a problem in appearance, please contact our company.

### Product List

Serial number	Item Name	Quantity
1	Turbine Flowmeter	1
2	Manual	1
3	Certificate	1

### Precautions

Users are expected to keep the "Product Qualification Certificate" properly and do not lose it.

---

## Contents

Chapter 1 Overview.....	1
Chapter 2 Working Principle.....	2
Chapter 3 Main Technical Parameters.....	3
Chapter 4 Structure And Installation.....	4
4.1. structure.....	4
4.2. Installation.....	6
Chapter 5 Flow meter operation method.....	10
5.1. Turbine flow sensor.....	10
5.2. Turbine flow meter with local display.....	11
5.3. Turbine flow meter without display.....	16
Chapter 6 Maintenance and overhaul.....	18
6.1. Precautions when using.....	18
6.2. Possible failures of the flow meter and solutions.....	19
Chapter 7 Warranty & After-sales Service.....	20
Chapter 8 Communication.....	21
8.1. Standard basis.....	21
8.2. Communication mode.....	21
8.3. RTU transmission mode.....	21
8.4. Function code definition.....	22
8.5. Example.....	23

## Chapter 1 Overview

The LWGY turbine flow meter is connected to the converter through the flow sensor, which can realize multiple functions such as pulse output, current output, and local display. The flow meter has the characteristics of high accuracy, wide measuring range, long life, simple operation and maintenance, etc. It can be widely used in food, medicine, petrochemical, metallurgy, paper making and other industries. It is an ideal instrument for flow measurement.

The flow meter is suitable for liquids that do not corrode stainless steel 304, 2Cr13, corundum ( $Al_2O_3$ ), cemented carbide, etc., and are free of impurities such as fibers and particles.

If the user needs a special type of flow meter, it can be supplied by agreement.

## Chapter 2 Working Principle

When the measured liquid flows through the flow meter sensor, its internal impeller rotates with the help of liquid kinetic energy. At this time, the impeller blade causes the magnetic resistance in the detection device to change periodically. Therefore, an electric pulse signal proportional to the flow rate is induced at both ends of the detection coil, and is amplified by the preamplifier then sent to the display unit. The single chip microcomputer system in the display unit calculates according to the number of pulses measured and the meter coefficient  $K$  of the flow meter, and displays the instantaneous flow rate and the accumulated total amount.

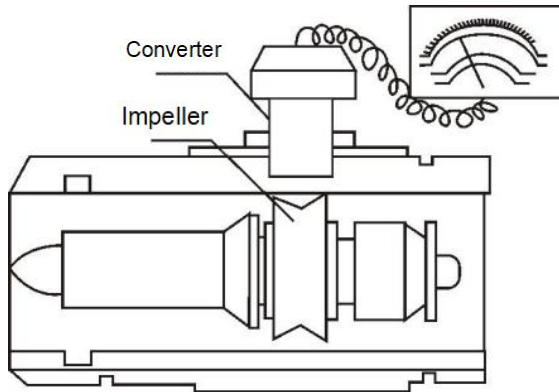

The relationship between the meter coefficient and instantaneous flow, frequency, pulse number, and cumulative total is:

$$K=f/Q \text{ and } K=N/V$$

In the formula:

$f$ —flow signal frequency (Hz)

$Q$ —instantaneous flow rate ( $m^3/s$ , or  $L/s$ )

$N$ —pulse number

$V$ —Total volume ( $m^3$ )

$K$ —Meter coefficient( $1/m^3$  or  $1/L$ )

### Chapter 3 Main Technical Parameters

Type	Main Technical Parameters
Measurement medium	Liquids (such as water, liquefied petroleum gas, finished oil, light crude oil, organic liquids, inorganic liquids and other liquids without fibre or particle impurities)
Nominal diameter	DN4mm ~ DN200mm
Accuracy	0.5%R, 1.0%R
Medium viscosity	It is less than $5 \times 10^{-6} \text{m}^2/\text{s}$ . For liquids larger than $5 \times 10^{-6} \text{m}^2/\text{s}$ , the meter should be calibrated in real liquid and used according to the new meter coefficient.
Medium temperature	$(-20 \sim +120)^\circ\text{C}$
Environmental conditions	Ambient temperature: $(-20 \sim +60)^\circ\text{C}$ Relative humidity: 5%~90%
Atmospheric pressure	$(86 \sim 106) \text{kPa}$
Power supply	3.6V、12VDC、24VDC
Output signal	Pulse signal, (4~20)mA current signal, Modbus communication
Ingress Protection	IP65

## Chapter 4 Structure And Installation

### 4.1. structure

The flowmeter structure is divided into thread, flange and clamp connection according to the different connection modes of the sensor part. The specific structure is shown in Figure 1 to Figure 5.

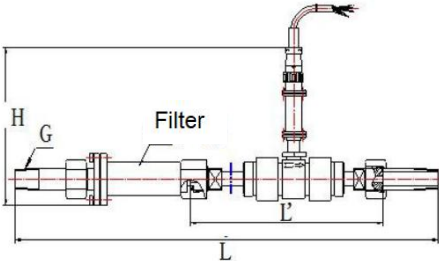

Figure 1 LWGY-4~10G flow meter structure and installation dimensions

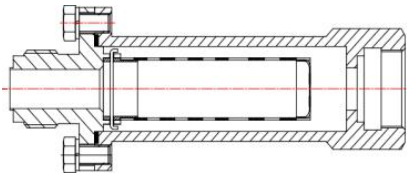

Figure 2 LWGY-4 ~ 10G filter

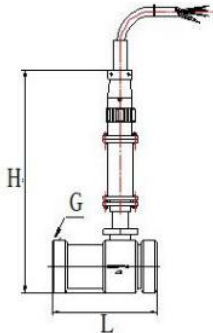

Figure 3 LWGYDN15~DN100 flow meter structure and installation dimensions

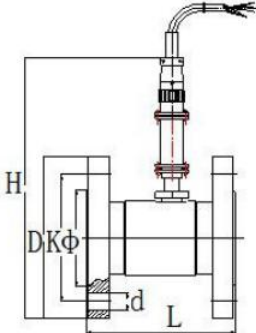

Figure 4 LWGY DN15~DN200 flow meter structure and installation dimensions



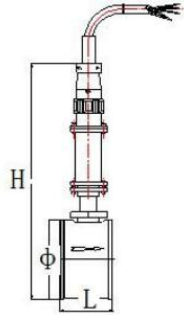

Figure 5 LWGY DN4~DN100 flow meter  
structure and installation dimensions

According to the different output modes of the converter, it is divided into battery-powered local display, 24V power supply without display, 24V power supply local display, pulse output, etc. The specific structure and dimensions are shown in Figure 6 to Figure 10, and the installation dimensions of the flow meter are shown in Tables 1-2.

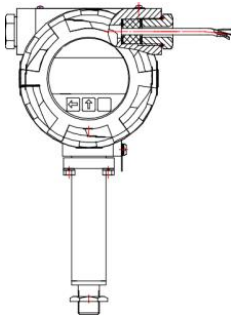

Figure 6 Partial dimensions of  
LWGY-2/34 converter (24V powered  
local display)

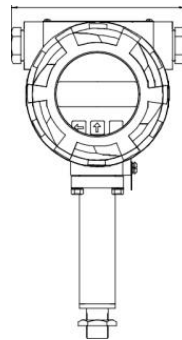

Figure 7 Partial dimensions of LWGY-1  
converter(Battery powered local display)

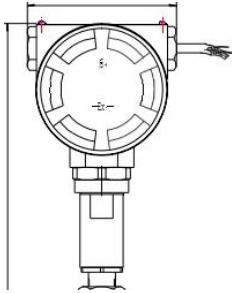

Figure 8 Partial dimensions of LWGY-0 converter(24V power supply without display)

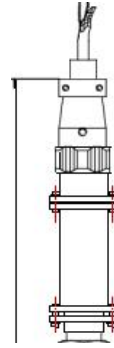

Figure 9 Partial dimensions of LWGY-i type converter (24V pulse output)

## 4.2. Installation

(1) The flow meter can be installed horizontally and vertically, and the fluid direction must be upward when installed vertically. The liquid should fill the pipe without air bubbles.

(2) During installation, the liquid flow direction should be consistent with the direction of the arrow indicating the flow direction on the flowmeter housing. There should be at least a straight pipe section of 10 times the diameter at the upstream end, and a straight pipe section of no less than 5 times the diameter at the downstream end.

(3) The flow meter should be far away from the external electromagnetic field. If it cannot be avoided, the necessary shielding measures should be taken.

(4) In order not to affect the normal delivery of liquid during maintenance, a bypass pipeline should be installed at the place where the flow meter is installed (Figure 10).

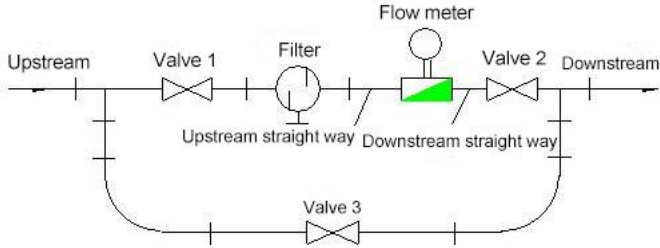

Figure 10 installation diagram of flow meter

(5) When the flow meter is installed in the open air, please do the waterproof treatment of the amplifier and plug.

**Table 1 Basic parameters and installation dimensions of turbine flow meter**

Diameter (mm)	Flow Range(m <sup>3</sup> /h)	Maximum pressure (MPa)	Installation type
4	0.04~0.25	6.3	Thread
6	0.1~0.6	6.3	Thread
10	0.2~1.2	6.3	Thread
15	0.6~6 / 0.3~6	6.3	Thread
20	0.8~8	6.3	Thread
25	1~10 / 0.5~10	6.3	Thread
		4.0	Flange
		25	Clamp
32	1.5~15	6.3	Thread
		4.0	Flange
40	2~20 / 1~20	6.3	Thread
		4.0	Flange
		25	Clamp
50	4~40 / 2~40	2.5	Live Flange
		4.0	Flange
		25	Clamp
65	8~80 / 4~80	4.0	Flange
80	10~100 / 5~100	2.5	Live Flange
		4.0	Flange
		25	Clamp

100	20~200 / 10~200	2.5	Live Flange
		2.5	Flange
		25	Clamp
150	30~300 / 15~300	2.5	Live Flange
		2.5	Flange
		5	Clamp
200	80~800 / 40~800	1.6	Flange
		2.5	Clamp

Diameter (mm)	L (mm)	G	L' (mm)	D (mm)	K (mm)	d	Holes	Φ (mm)	Y (mm)	f (mm)
4	394	R3/8	194							
6	430	R3/8	230							
10	550	R3/8	350							
15	75	G1								
20	80	G1								
25	100	G1 1/4								
	100			115	85	Φ14	4	Φ57		
	100							Φ50.8	Φ52.4	5
32	140									
	140				Φ100	Φ18	4	Φ65	4	
40	140	G2								
	140			Φ150	Φ110	Φ18	4	Φ75	Φ76	3
	50							Φ73	Φ76.4	5
50	150			Φ160	Φ125	Φ18	4	Φ71	Φ72	3
	150			Φ165				Φ87	Φ88	3
	60							Φ92	Φ93.6	5
65	200			Φ185	Φ145	Φ18	8	Φ118		
80	200			Φ195	Φ160	Φ18	8	Φ103	Φ104	3
	200			Φ200				Φ120	Φ121	3
	80							Φ127	Φ128.6	5
100	220			Φ220	Φ180	Φ18	8	Φ122	Φ123	3
	220			Φ235	Φ190	Φ22	8	Φ149	Φ150	3
	100							Φ157	Φ158.6	5
150	300			Φ300	Φ250	Φ26	8	Φ178	Φ179	3
	300							Φ203	Φ204	3
	150							Φ216	Φ217.5	5
200	360			Φ340	Φ295	Φ22	12	Φ266		
	200							Φ259	Φ260	3.5

**Table 2 Flow meter installation dimensions (height)**

Diameter(mm)	Installation Type and pressure	The height of different converters H (mm)		
		Battery powered local display	24V Without display	24V Local display
4	G06	254	204	254
6	G06	254	204	254
10	G06	254	204	254
15	G06	254	204	254
25	G06	265	215	265
	F04	300	250	300
	E25	269	219	269
40	G06	280	230	280
	F04	325	275	325
	E25	286	236	286
50	H03	335	285	335
	F04	338	288	338
	E25	304	254	304
65	F04	357	307	357
80	H03	368	318	368
	F04	370	320	370
	E25	336	286	336
100	H03	391	341	391
	F03	398	348	398
	E25	362	312	362
150	H03	456	406	456
	F03	456	406	456
	E05	415	365	415
200	F02	500	450	500
	E03	461	411	461

## Chapter 5 Flow meter operation method

### 5.1. Turbine flow sensor

#### 5.1.1. Main technical parameters

Power supply: +12V DC, +24V DC (maximum voltage +26VDC)

Output signal: pulse signal

#### 5.1.2. Field connection method

The connection between the flow meter and the display instrument can be selected according to the power supply of the instrument(Figure 14).

Warning: When wiring the instrument, it must be operated after power off.

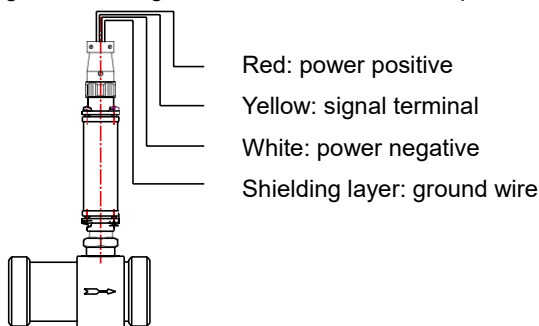

Figure 11 Wiring diagram of sensor and display instrument

#### 5.1.3. Sensor supporting display instrument

Intelligent display instrument: It can display the cumulative quantity and instantaneous quantity, the display error is better than 0.2% FS, 8-segment broken line non-linear correction function, the alarm output can be set as the instantaneous upper and lower limit alarm or cumulative quantity preset output.

Power failure record function can record the total power failure time. Number of power outages and power-on time. Output current: 4~20mA, 0~10mA; external power supply: 24V DC, 12V DC, optional RS485 communication interface.

Dimensions: 160×80×125 or 80×160×125.

Display instrument: used for liquid quantitative filling or batching control, basic

error 0.2%, 8-digit total and 6-digit batch display.

## **5.2. Turbine flow meter with local display**

### **5.2.1. Main technical parameters**

Power supply: LWGY-1—3.6V lithium battery (19Ah built-in)

LWGY-2/3/4—+24V DC power supply

display content: instantaneous flow 6 digits, cumulative total 8 digits

Output mode: LWGY-1—pulse output (optional, need external power supply)

LWGY-2/3/4—4~20mA current output, pulse output (optional) ModBus communication (optional), the output function cannot be used at the same time.

### **5.2.2. Display operation method**

#### **(1) Button function**

① In the automatic measurement state, the Button function:

F key: enter the parameter setting state;

Up key: Cyclic display of turbine frequency, density, meter coefficient, unit code, instantaneous flow and Totalizer.

Left button: No function temporarily

#### **② Key function in parameter setting state**

Press the left button to display the menu items in a forward cycle;

Press the middle button to display the menu items in reverse cycle;

Press the right button to confirm and enter the parameter setting interface of the corresponding menu item, you can modify the parameters;

in the parameter setting interface:

Press the left button to shift or scroll;

press the middle button to scroll ;

Press the right button to confirm and save the corresponding parameters and exit the parameter setting interface.

(2) LCD screen

Double row segment LCD, no decimal point at the end of the upper and lower rows, use "\_" instead of the decimal point.

Upper row: Q xxxxxx, 6-digit instantaneous flow, the unit is shown in Table 2;

Bottom row: xxxxxxxx, 8-digit cumulative total, the unit corresponds to the instantaneous flow.

(3) Parameter setting

Press the F key to enter the password input interface:

Enter the level 1 user password "00001111", and then press the F key to enter the user setting menu state, and the user can view and modify items 1-9.

Enter the level 2 administrator password "0000XXXX" (manufacturers used for debugging, not provided to customers), and then press the F key to enter the administrator setting menu status, and the user can view and modify items 1 to 27.

PS: The password error system returns to the running state;

In the setting state, first press the left button, and then press the middle button at the same time to return to the running state

Restore factory settings: Press the right button, enter the factory reset password "0000XXXX" (manufacturers used for debugging, not provided to customers), and then press the right button to confirm, you can restore the parameters to the factory data.

The Totalizer is cleared:

① Press the F key, enter the cumulative reset password "00005170"

(manufacturers used for debugging, not provided to customers), and then press the F key to confirm, the cumulative total can be cleared.

② Clear the reed pipe. (Optional for this function) The unit of accumulated pulse equivalent is L/P.

The bar code on the right side of the LCD simulates the instantaneous flow rate, and each bar represents 10% of the instantaneous flow rate.



Table 3 User setting menu

NO.	Setting parameters	Parameter symbol	Default	Description	Level
1	range	FH	100.000	Upper limit of flow	1
2	Small signal removal	FL	0.001	Lower limit of flow	1
3	Correction factor	Fn	1.000	Set to 1 when no correction is needed	1
4	unit	E	1	The units represented by 0-9 are: m <sup>3</sup> /s, m <sup>3</sup> /h、L/s、L/h、Kg/s、Kg/h、g/s、 g/h、t/s、t/h	1
5	density	dEn	1000.00	Density unit: Kg/m <sup>3</sup>	1
6	Slave address	Adr	01	00-99 (No 485 communication when battery powered)	1
7	Communication rate	bPs	1200	1200、2400、4800、9600 (No 485 communication when battery powered)	1
8	Output options	FO	0	0: No pulse output; 1: Cumulative pulse output (from artery width) 2: Accumulated pulse output (10ms pulse width) 3: Current output (invalid when powered by battery)	1
9	Cumulative pulse equivalent	Fdd	0.01	0.0001、0.001、0.01、0.1、1、2、5、10、100、1000、10000、100000 (unit: L/P)	1
10	Damping coefficient	dt	0.0000	The larger the value, the greater the damping, 0~60	1
11	Meter factor	U	100.000	Average calibration factor	2
12	Segment compensation enable	CP	0	0: No compensation 1: Compensation	2
13	Calibration frequency 1	Fr1	250.000	First frequency	2
14	Calibration frequency 1	U1	100.000	The coefficient corresponding to frequency Fr1	2
15	Calibration frequency 2	Fr2	500.000	Second frequency	2
NO.	Setting parameters	Parameter symbol	default	description	level
16	Calibration factor 2	U2	100.000	The coefficient corresponding to frequency Fr2	2
17	Calibration frequency 3	Fr3	750.000	Third frequency	2
18	Calibration factor 3	U3	100.000	The coefficient corresponding to frequency Fr3	2
19	Calibration factor 4	Fr4	1000.00	Fourth frequency	2

20	Calibration factor	4	U4	100.000	The coefficient corresponding to frequency Fr4	2
21	Calibration factor	5	Fr5	1250.00	Fifth frequency	2
22	Calibration factor	5	U5	100.000	The coefficient corresponding to frequency F5	2
23	Calibration factor	6	Fr6	1500.00	Sixth frequency	2
24	Calibration factor	6	U6	100.000	The coefficient corresponding to frequency F6	2
25	Calibration factor	7	Fr7	1750.00	Seventh frequency	2
26	Calibration factor	7	U7	100.000	The coefficient corresponding to frequency Fr7	2
27	Calibration factor	8	Fr8	2000.00	Eighth frequency	2
28	Calibration factor	8	U8	100.000	The coefficient corresponding to frequency Fr8	2

Note: Frequency points 1~8 are arranged in order from small to large. When the CP value is "0", items 13~28 are not displayed,

(4) Wiring instructions

LWGY-□□□□1 battery-powered turbine flow meter

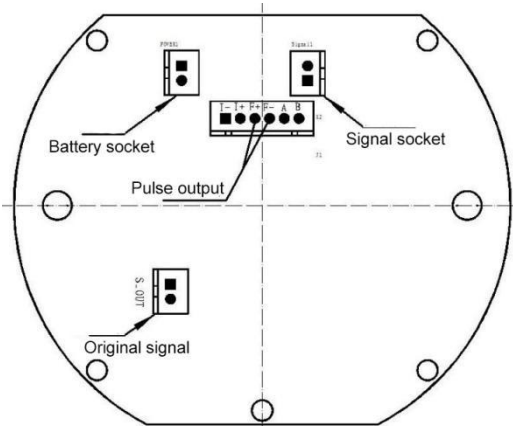

LWGY-□□□□2/3/4 Turbine Flow meter

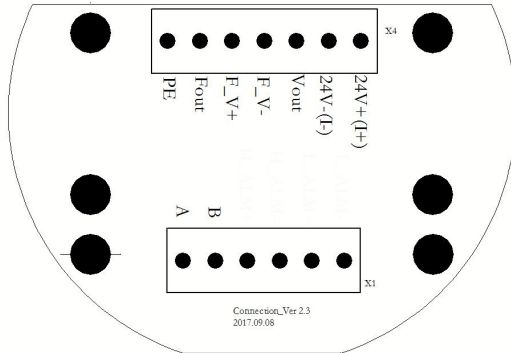
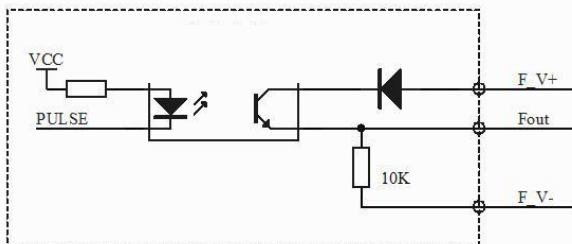

Figure 12.Schematic diagram of internal wiring

Table 4

24V+ (I+)	24V Power + (current +)
24V- (I-)	24V Power-(current -)
Vout	Voltage output+
F_V-	Pulse output power supply-
F_V+	Pulse output power supply+
Fout	Pulse output
FE	Ground
B	Modbus communication line B
A	Modbus communication line A

Pulse output wiring diagram:



When there is no sampling resistance inside the system, F\_V+ is connected to the positive pole of the power supply, F\_V- is connected to the negative pole of the power supply, and Fout is connected to the pulse signal;

When there is a sampling resistor inside the system, F\_V+ is connected to the

positive pole of the power supply, Fout is connected to the pulse signal, and F\_V- does not need to be connected.

note! The pulse signal power supply voltage range is DC5V~24V.

#### (5) Battery replacement

Accumulatively powered on for two years, unconditionally replace the battery. If the meter does not display or displays abnormally within the battery lifespan, and the measured battery voltage is lower than 2.8V, you should immediately cut off the power supply and replace the battery, otherwise the circuit unit in the meter will be damaged.

When replacing the battery, pay attention to the polarity of the battery to be consistent with the battery box label, and not reverse it. Each time the cover is opened and then assembled, the front and back covers of the instrument should be tightened.

### **5.3. Turbine flow meter without display**

#### **5.3.1. Main technical parameters**

Power supply: +24V DC

Output signal: 4~20mA current output

#### **5.3.2. Usage**

(1) The complete connection method of the flow meter (see Figure 14).

(2) Schematic diagram of internal wiring (see Figure 15)

(3) Schematic diagram of fine adjustment of full-scale flow (see Figure 17)

Full scale fine-tuning button: press K1 and K2 at the same time, LED2 lights up to enter the adjustment mode and release the button, press K1 to increase the current, and press K2 to decrease the current. It will automatically exit the adjustment mode if there is no operation for 1 minute.

\*Note: The current has been adjusted before the product is sold, please do not adjust it at will;

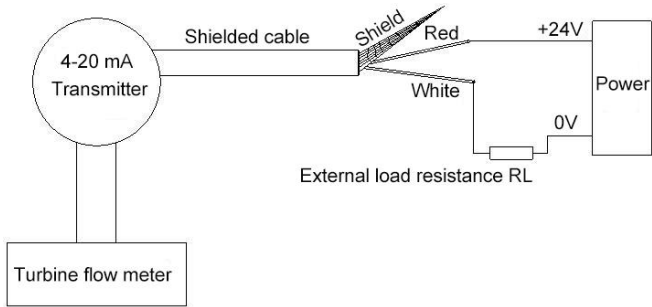
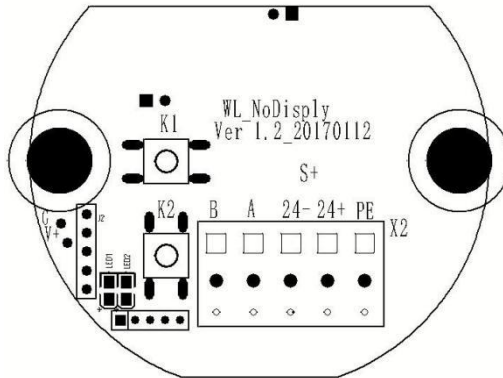

Figure 16 Schematic diagram of external wiring



PE	Ground
24+	24V power supply+
24-	24V power supply
A	485 Communication A
B	485 communication B

Figure 17 Schematic diagram of internal wiring diagram

## **Chapter 6 Maintenance and overhaul**

### **6.1. Precautions when using**

- (1) When using, keep the tested liquid clean and free of impurities such as fibers and particles.
- (2) Each time the flow meter is used, valve 1 should be slowly opened (see Figure 11), and the pipe should be filled with liquid slowly, and then downstream valve 2 should be slowly opened. The impact of the fluid. Otherwise the sensor may be damaged!
- (3) It is recommended that the flow meter maintenance cycle should not exceed half a year. Clean the impeller and the cavity parts of the sensor during maintenance and be careful not to damage it. Pay attention to the correct position of each part when assembling.
- (4) When the flow meter is not in use, the liquid inside the sensor should be cleaned, and protective sleeves should be added to both ends of the sensor to prevent dust from entering, and stored in a dry place.
- (5) The configured filter should be cleaned and replaced regularly, and the internal liquid should be cleaned when not in use, with a dust cover, and stored in a dry place.
- (6) The transmission cable of the flow meter can be laid overhead or buried (the iron pipe should be covered when buried). The cable length is 10m when the product leaves the factory.

## 6.2. Possible failures of the flow meter and solutions

Table 5 Common faults and solutions of flow meters

Failure phenomenon	the reason	solutions
No display on display instrument (Or no current signal)	<ol style="list-style-type: none"> <li>1. The power is not connected or the fuse is blown</li> <li>2. The display instrument is faulty</li> <li>3. Battery failure</li> </ol>	<ol style="list-style-type: none"> <li>1. Turn on the power or replace the fuse</li> <li>2. Overhaul the display instrument</li> <li>3. Replace the battery</li> </ol>
The display instrument has display on the calibration signal but no display on the flow signal (or the output current is incorrect)	<ol style="list-style-type: none"> <li>1. The sensor and display instrument wiring is wrong</li> <li>2. Amplifier failure</li> <li>3. The converter (coil) is open or shorted</li> <li>4. The impeller is stuck</li> <li>5. No fluid flow or blockage in the pipeline</li> </ol>	<ol style="list-style-type: none"> <li>1. Check the correctness and quality of the wiring</li> <li>2. Repair or replace the amplifier</li> <li>3. Repair or replace the coil</li> <li>4. Clean sensor and pipeline...</li> <li>5. Open the valve or pump and clean the pipeline</li> </ol>
Incorrect measurement or unstable display (or incorrect output current)	<ol style="list-style-type: none"> <li>1. The actual flow exceeds the measuring range of the sensor</li> <li>2. The meter coefficient K is set incorrectly</li> <li>3. The sensor is entangled by fiber impurities</li> <li>4. There are bubbles in the liquid</li> <li>5. There is a strong electromagnetic field near the sensor</li> <li>6. The sensor bearing and shaft are severely worn</li> <li>7. The sensor cable shielding layer or other grounding wires are disconnected from the line grounding wire or have poor contact</li> <li>8. Display instrument failure</li> </ol>	<ol style="list-style-type: none"> <li>1. Adjust the measured flow rate to match the measuring range of the sensor</li> <li>2. Make the meter coefficient K set correctly</li> <li>3. Clean the sensor parts</li> <li>4. Take degassing measures to eliminate bubbles</li> <li>5. Stay away from interference sources or take shielding measures</li> <li>6. Replace the guide or impeller shaft</li> <li>7. Check the wiring</li> <li>8. Overhaul display instrument</li> </ol>

## **Chapter 7 Warranty & After-sales Service**

We promise to the customer that the hardware accessories provided during the supply of the instrument have no defects in material and manufacturing process. From the date of the purchase, if the user's notice of such defects is received during the warranty period, the company will unconditionally maintain or replace the defective products without charge, and all non customized products are guaranteed to be returned and replaced within 7 days.

Disclaimers:

- During the warranty period, product faults caused by the following reasons are not in the scope of Three Guarantees service
- Product faults caused by improper use by customers.
- Product faults caused by disassembling, repairing and refitting the product.

After-sales service commitment:

- We promise to deal with the customer's technical questions within 2 hours.
- For the instruments returned to the factory for maintenance, we promise to issue the test results within 3 working days and the maintenance results within 7 working days after receiving them.



## Chapter 8 Communication

The communication protocol is designed for the industrial application of bus turbine flow meter, which is version 1.0, which is mainly used for real-time data acquisition, flow measurement and flow accumulation control, and currently only supports register readout function.

### 8.1. Standard basis

GB/T 19582-2008 The standard is based on the industrial automation network specification targeted by the Modbus protocol.

### 8.2. Communication mode

The Modbus serial link is built in 485mi A, and the hardware interface adopts 485communication mode. At present, the interface supports up to 32 extension networks.

The communication mode is RTU mode, the baud rate range 1200、2400、4800、9600bps。

### 8.3. RTU transmission mode

- The message contains two 4-bit hexadecimal characters in each 8-bit byte, and the message needs to be transmitted in a continuous character stream.
- Format of each byte (10 bits).
  - (1) 1 start bit.
  - (2) 8 data bits, first send the least significant bits.
  - (3) 1 stop bit.
- Message frame description.

Address(1) + Function code(1)+ Data (0-252)+ CRC check(1).

- Time sequence

The idle interval of at least 3.5character time distinguishes the message frame, which is tentatively set as a fixed time 100ms to determine the beginning of the data frame.

#### 8.4. Function code definition

- Read register

Read the contents of the register in the instrument, including a variety of information parameters, high in the low address and low in the high address.

Big end mode:

Table 6

Name	Register address	Data type	Number of bytes
Instantaneous flow	0	float	4
Cumulative flow	4	float	4
Turbine frequency	8	float	4
Upper limit of flow (range)	12	float	4
Lower limit of flow	16	float	4
Unit	20	Char	1

Unit comparison table :

Table 7

Unit code	Unit	Unit code	Unit
0	m <sup>3</sup> /s	5	kg/h
1	m <sup>3</sup> /h	6	g/s
2	l/s	7	g/h
3	l/h	8	t/s
4	kg/s	9	t/h

## 8.5. Example

Table 8

40001: <0000H>	40011: <0000H>
40002: <0000H>	40012: <0000H>
40003: <4007H>	40013: <0000H>
40004: <EAD2H>	40014: <0000H>
40005: <0000H>	40015: <0000H>
40006: <0000H>	
40007: <42C8H>	
40008: <0000H>	
40009: <3A83H>	
40010: <126FH>	

- (1) 40001-40002 : 00 00 00 000.000 Instantaneous flow.
- (2) 40003-40004 : 40 07 EA D2 2.12371 Cumulative flow.
- (3) 40005-40006 : 00 00 00 000.000 Turbine frequency.
- (4) 40007-40008 : 42 C8 00 00 100 m3/s Upper limit of flow.
- (5) 40009-40010 : 3A 83 12 6F 0.001 m3/s Lower limit of flow.
- (6) 40011: 00m3/s unit.